

"H-TYPE" FRONT SET

DS-543

HIGH TORQUE MOVEMENT

97 West Street, Medfield, MA 02052

p: 508.359.4396 f: 508.359.4482

www.electrictime.com

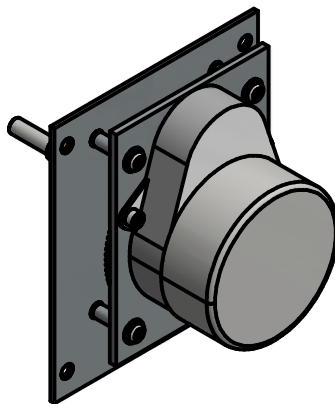
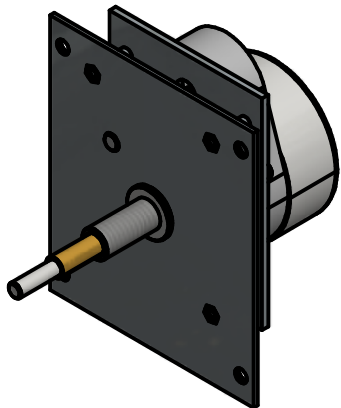
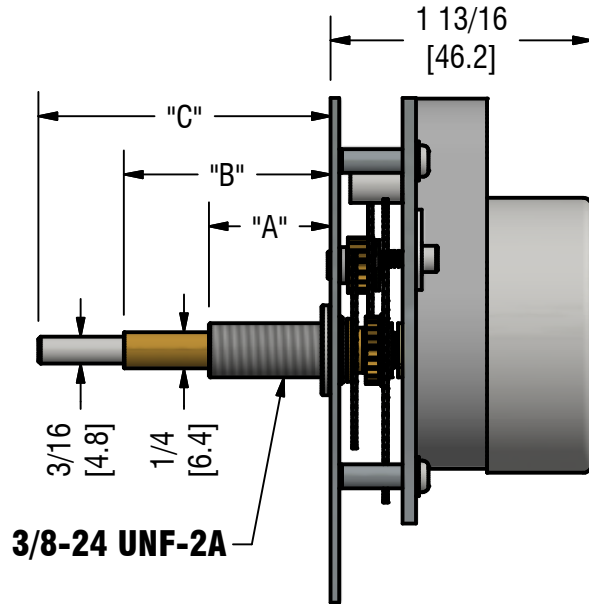
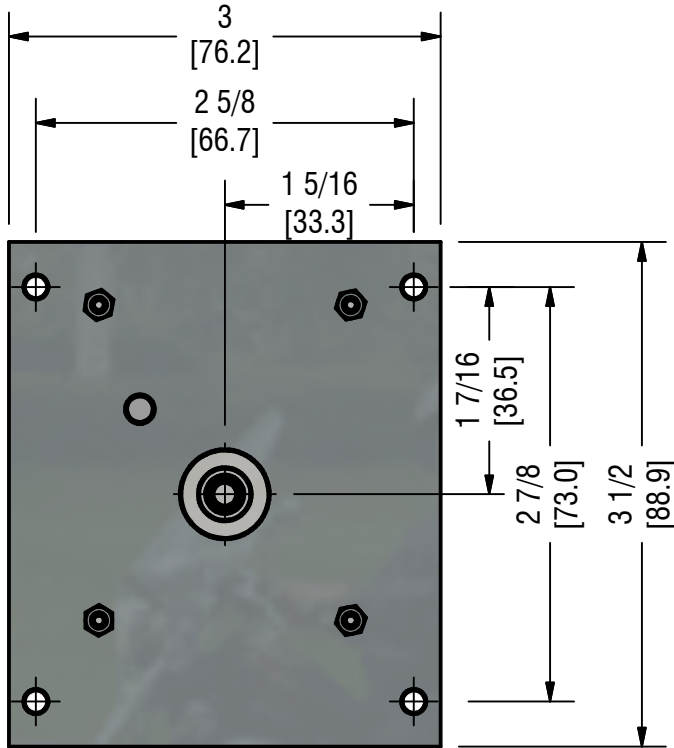

MECHANICAL SPECIFICATIONS:

- UP TO Ø60" [152cm] DIAL WITH UNPROTECTED HANDS
- FRONT SET ONLY
- INDOOR USE ONLY
- 115Vac 60HZ OPERATION
- AVAILABLE WITH 4 HOLE OR CENTER HOLE MOUNTING HARDWARE
- COMPATIBLE WITH "HMI" HAND HUBS
- APPROXIMATE WEIGHT = 1 LB [450g]

FRONT ISOMETRIC VIEW

REAR ISOMETRIC VIEW

"H TYPE" FRONT SET HIGH TORQUE MOVEMENT			
SHAFT LENGTH	A	B	C
MOVT-HHT-C6A	27/32" [2.1cm]	1-7/16" [3.6cm]	2" [5.1cm]
MOVT-HHT-C8A	1-7/8" [4.8cm]	2-3/8" [6.0cm]	2-15/16" [7.5cm]