

C1 STYLE DIAL GEAR ASSEMBLY

DS-523A

97 West Street, Medfield, MA 02052

p: 508.359.4396 f: 508.359.4482

www.electrictime.com

Description:

- Replaces existing dial gear assemblies while utilizing the original drive mechanism.
- Up to $\varnothing 96"$ [2400] with unprotected hands
- Up to $\varnothing 144"$ [3700] with protected hands
- Clamp collar for easy mounting and adjustment
- Compatible with Electric Time Co. XMI 4-way clock movement.
- Uses Electric Time Co. standard C1 style clamp hand hubs.
- Shafting, universal joints and slide couplings available. Contact Electric Time Co. for more details.

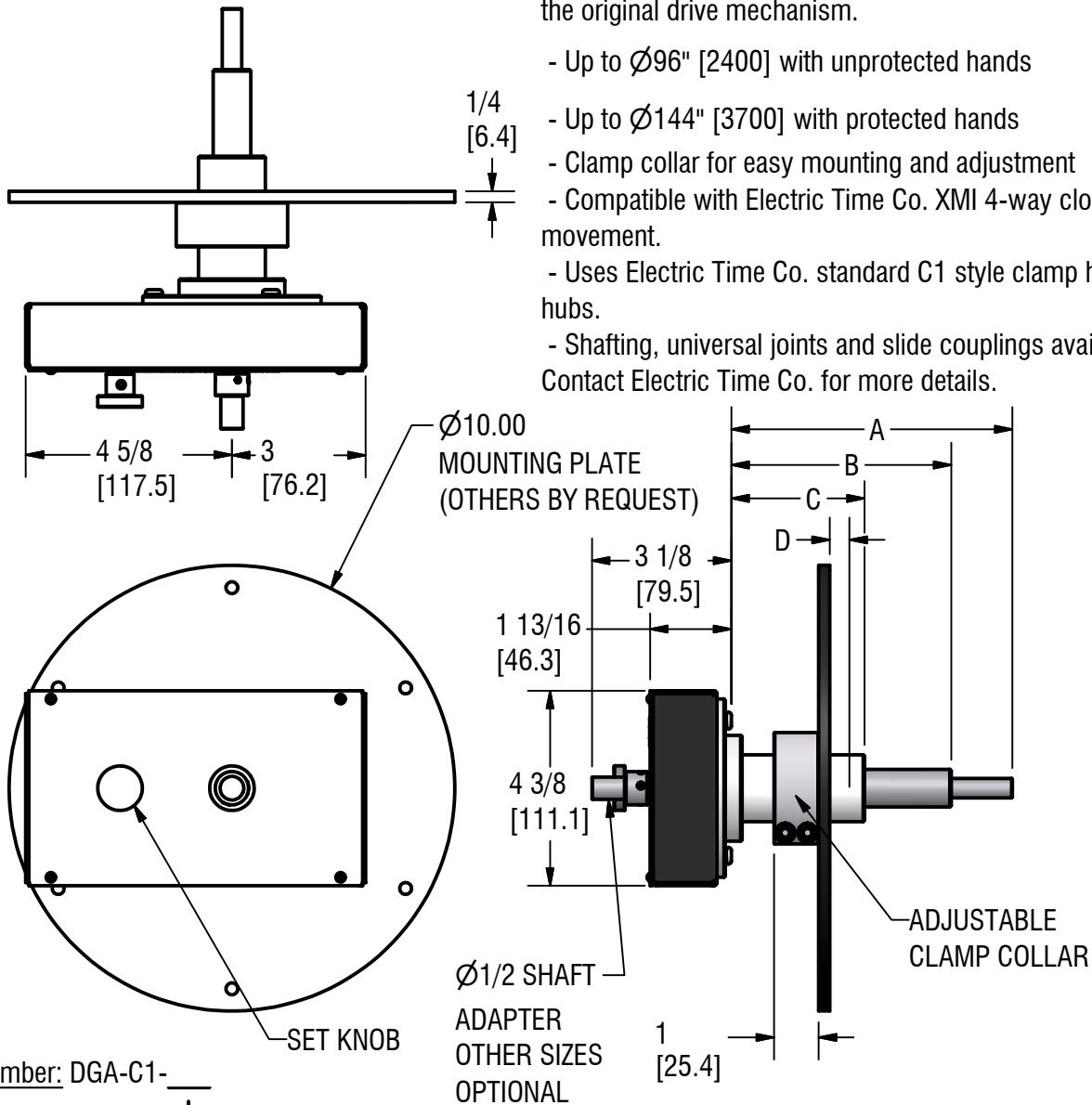

	A	B	C	D*	NET WEIGHT
G1	6 5/16 [160]	4 15/16 [125]	3 1/16 [78]	1 [25]	8 lb
G3	9 3/4 [248]	8 3/8 [213]	6 1/2 [165]	4 3/4 [121]	9 lb
G10	20 3/4 [527]	19 7/16 [494]	17 9/16 [446]	14 3/4 [375]	11 lb

* MAX DIAL + WALL THICKNESS

ALL DIMENSIONS: INCHES [MILLIMETERS]

NOTE: SPECIFICATIONS SUBJECT TO
CHANGE WITHOUT NOTICE

Copyright 2007 all rights reserved