

H TYPE POINTER MOVEMENT

DS-520

45 West Street, Medfield, MA 02052

p: 508.359.4396 f: 508.359.4482

www.electrictime.com

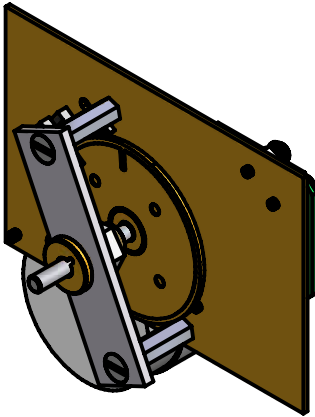

FRONT ISOMETRIC VIEW

The HMI-P movement is a fast setting single indicator movement. Standard functions include; moon dial, day of the week, day of the month, month, thermometer and barometer.

MECHANICAL SPECIFICATIONS

- Up to $\varnothing 30''$ dial with protected hands
- Consult Electric Time Co. for recommended movement and hand mounting procedures
- Approximate weight = 1/2 lb

ELECTRICAL SPECIFICATIONS

- 24VDC-50/60 Hz Stepper motor
- RS485 Communication between Electric Time Co. 99B-MI Clock Controller and the pointer movement
- Up to 16 pointer movements can be connected to a single control.

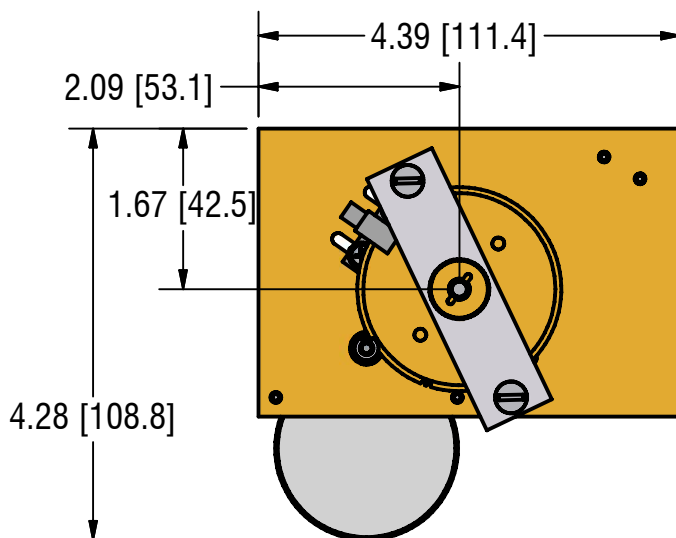

FRONT VIEW

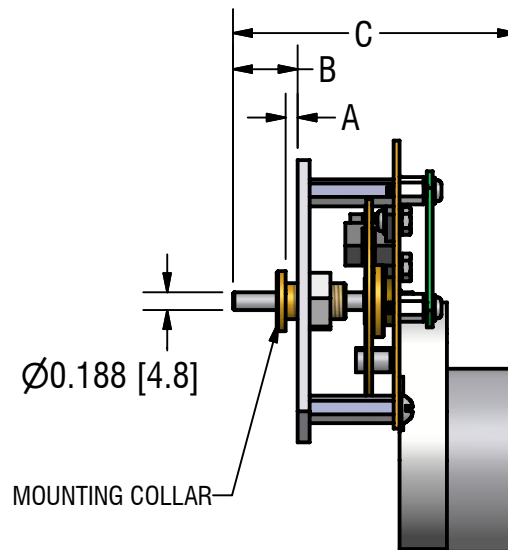

SIDE VIEW

PART NUMBER: MOVT-HMI-P-

	A*	B**	C
C4	7/16 [11]	11/16 [17]	2 15/16 [75]
C6	7/16 [11]	1 9/16 [39]	3 13/16 [97]
C8A	7/16 [11]	2 3/16 [55]	4 7/16 [113]

*MAX DIAL THICKNESS

ALL DIMENSIONS: INCHES [MILLIMETERS]

** +3/16 [5]/ -3/8[10] (SPECIAL ORDER)

Note: Specifications subject to change without notice