

**HMI SWEEP SECOND MINUTE IMPULSE
MOVEMENT**

DS-517

45 West Street, Medfield, MA 02052

p: 508.359.4396 f: 508.359.4482

www.electrictime.com

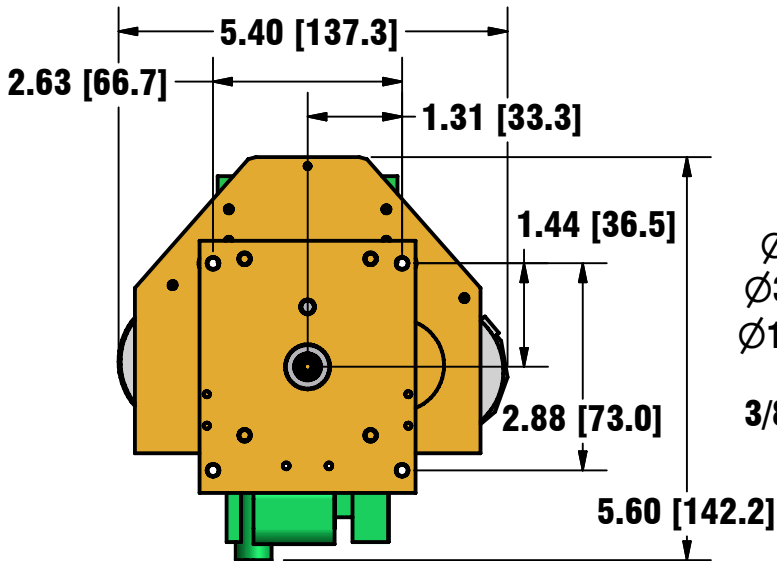

FRONT VIEW

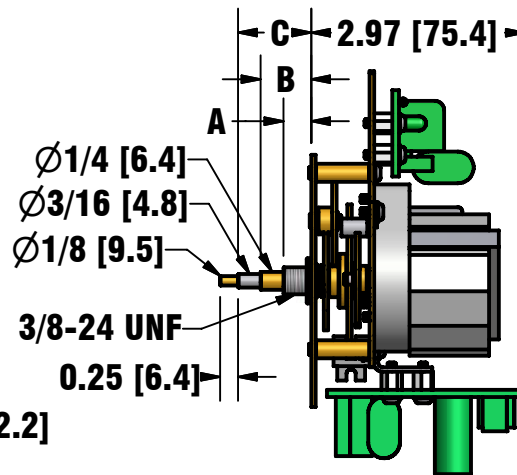

SIDE VIEW

MECHANICAL SPECIFICATIONS:

1. UP TO $\varnothing 30$ [760] DIAL WITH PROTECTED HANDS
2. SWEEP OR STEPPING SECOND HAND OPERATION

ELECTRICAL SPECIFICATIONS:

1. 24VAC 360mA 50/60hz (SWEEP) 24VAC 200mA 50/60hz AND 24VDC 200mA (STEP)
2. MI OPERATION- 8sec/min RUN TIME
3. ALTERNATING DRIVE SIGNAL MINUTE IMPULSE OPERATION (USING ELECTRIC TIME CO 99B-MI CLOCK CONTROLLER)

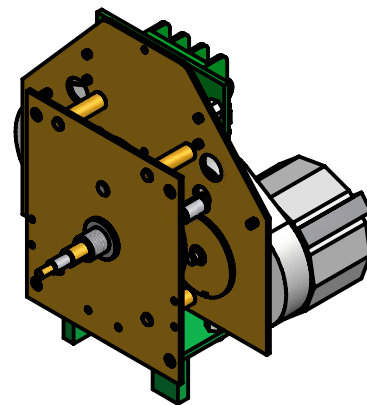

FRONT ISOMETRIC VIEW

MOV'T	A	B	C
C4	3/8 [10]	11/16 [17]	1 1/32 [26]
C6	27/32 [21]	1 13/32 [36]	1 7/8 [48]
C8A	1 7/8 [48]	2 3/16 [56]	2 1/2 [64]

in [mm]

Note: Specifications subject to change without notice