

## C1MI-I STYLE ILLUMINATED HAND MOVEMENT INSTALLATION

DS-501A

45 West Street, Medfield, MA 02052

p: 508.359.4396 f: 508.359.4482

[www.electrictime.com](http://www.electrictime.com)

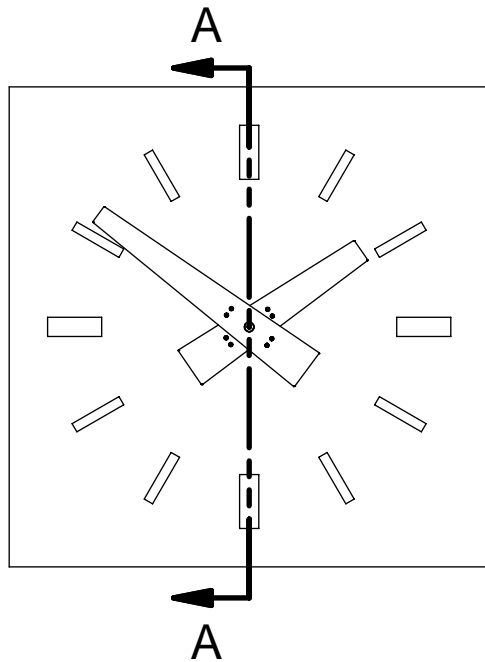

**FRONT VIEW**

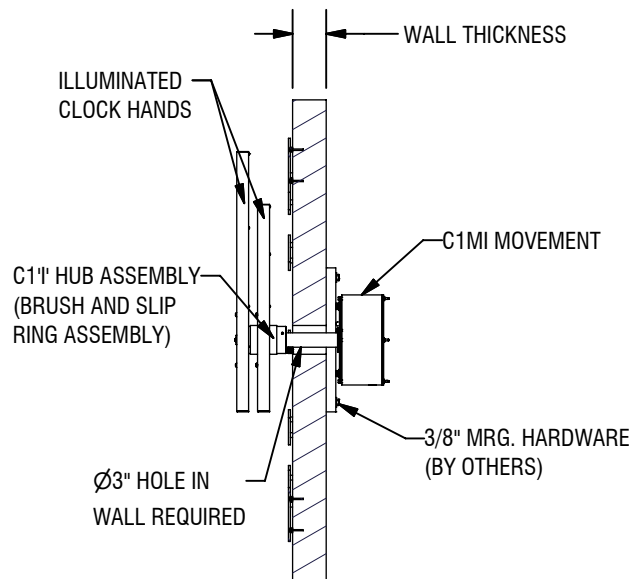

**SECTION VIEW**

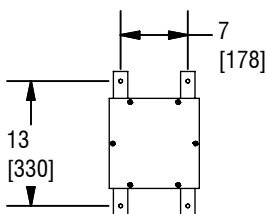

**MOVEMENT MOUNTING**

### SPECIFICATIONS

- UP TO  $\phi 72$ " [1800] DIAL
- CONSULT ELECTRIC TIME CO. FOR RECOMMENDED MOVEMENT AND HAND MOUNTING PROCEDURES
- JUNCTION BOX PROVIDED, MOUNTS TO INSIDE WALL SURFACE (TYPICAL)
- 115VAC OR 230VAC OPERATION, SPECIFY WHEN ORDERING
- SPLIT COVER AVAILABLE FOR WALL OPENING, SPECIFY WHEN ORDERING
- NEON OR LED ILLUMINATION, SPECIFY WHEN ORDERING
- VARIOUS ILLUMINATION COLORS AVAILABLE, CONSULT ELECTRIC TIME CO FOR DETAILS.
- HALO, BACKLIT AND CUSTOM DESIGNS AVAILABLE.

PART NUMBER: MOV-T-C1MI-    

	WALL THICKNESS	NET WEIGHT (lb)	SHIPPING WEIGHT (lb)
G1	1/4 [ 6.4 ]	16	25
G3	3 1/2 [ 88.9 ]	17	35
G8	10 1/2 [ 266.7 ]	20	55
G10	14 3/8 [ 365.1 ]	21	55

NOTE: SPECIFICATIONS  
SUBJECT TO CHANGE  
WITHOUT NOTICE.

ALL DIMENSIONS: INCHES [MILLIMETERS]