

**B28MI MINUTE IMPULSE MOVEMENT**

**DS-5A**

97 West Street, Medfield, MA 02052

p: 508.359.4396 f: 508.359.4482

www.electrictime.com

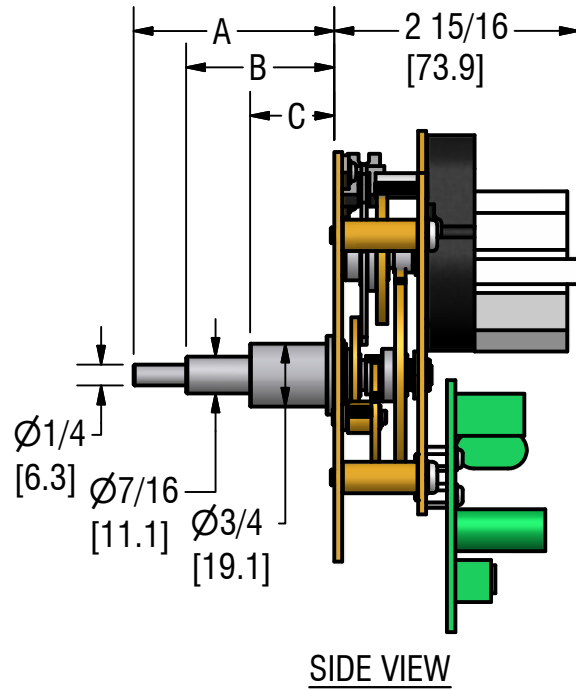
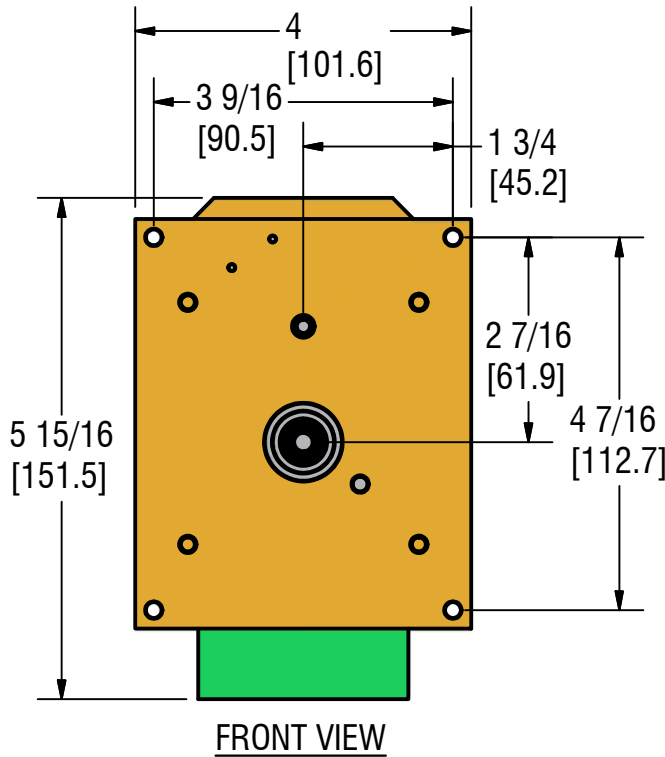

MECHANICAL SPECIFICATIONS

- UP TO Ø48" DIAL  
WITH UNPROTECTED HANDS
- UP TO Ø60" DIAL W/ PROTECTED HANDS
- CONSULT ELECTRIC TIME CO. FOR RECOMMENDED MOVEMENT AND HAND MOUNTING PROCEDURES
- APPROXIMATE WEIGHT = 2-1/2 lbs.  
(1.13 kg)

ELECTRICAL SPECIFICATIONS

- 24VAC-50/60Hz-200mA-5W
- ALTERNATING DRIVE SIGNAL MINUTE IMPULSE OPERATION (USING ELECTRIC TIME CO. 99B-MI CLOCK CONTROLLER)

\*SWEEP SECOND HAND VERSION AVAILABLE, CONSULT ELECTRIC TIME CO.

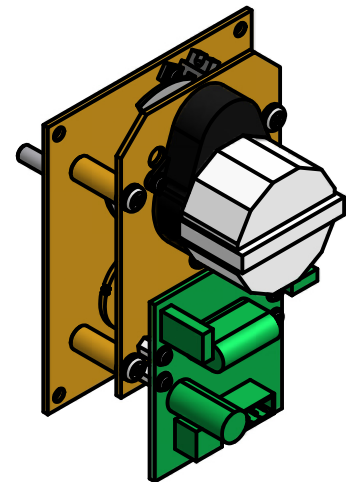
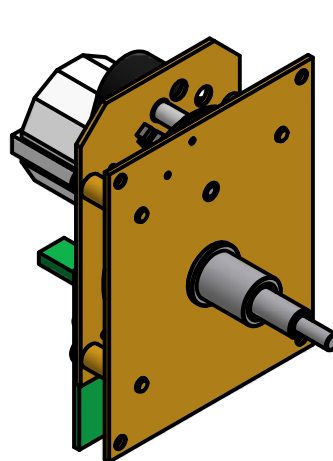

	A	B	C
<b>G1</b>	2 3/8 [ 60 ]	1 3/4 [ 44 ]	1 [ 25 ]
<b>G7</b>	3 1/4 [ 83 ]	2 3/4 [ 70 ]	2 1/4 [ 57 ]
<b>G8</b>	6 [ 152 ]	5 1/4 [ 133 ]	2 1/4 [ 57 ]

DIMENSIONS: INCHES [MILLIMETERS]

Note: Specifications subject to change without notice