

Note: Specifications subject to change without notice.

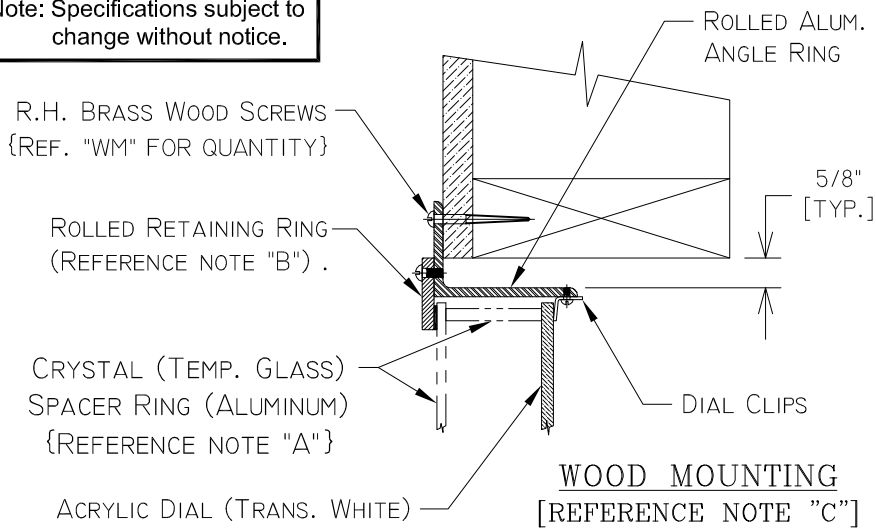

MOUNTING OPTIONS - FLUSH CLOCKS
2400, 4600 & 8000 SERIES

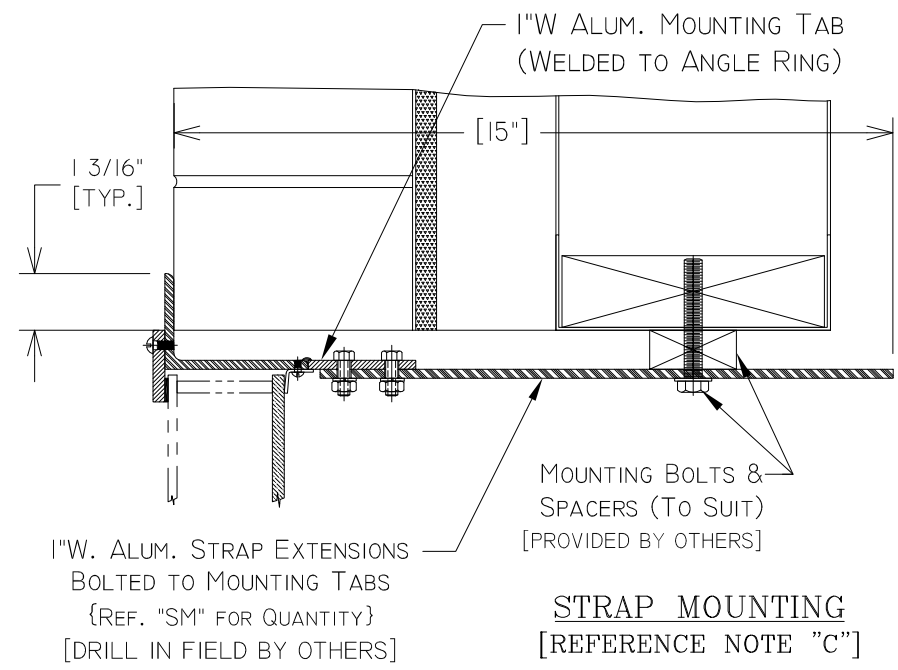

2400 SERIES & 8000 SERIES (60" & BELOW)				
2418 & 8018	19-5/8"	9-1/2"	6	4
2424 & 8024	25-5/8"	9-1/2"	6	4
2430 & 8030	32"	10-1/2"	6	4
2436 & 8036	38"	10-1/2"	8	4
2442 & 8042	44"	10-1/2"	8	4
2448 & 8048	50"	10-1/2"	10	6
2454 & 8054	56"	10-1/2"	10	6
2460 & 8060	63"	10-1/2"	12	6
4600 SERIES				
4672	76-1/8"	11-1/2"	20	8
4684	88-1/8"	11-1/2"	20	12
4696	99-5/8"	11-1/2"	26	12
8000 SERIES (72" & ABOVE)				
8072	71-1/2"	11-1/2"	20	8
8084	84-1/2"	11-1/2"	20	12
8096	95-1/2"	11-1/2"	26	12
CLOCK STYLE	I.D./±3/8" WALL OPENING	OVERALL DEPTH	"WM" QUANTITY	"SM"/"MM" QUANTITY

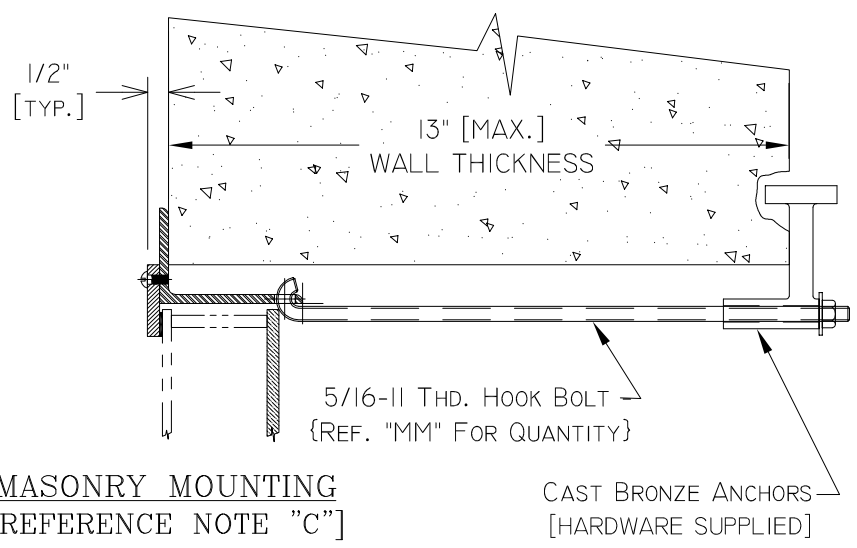

*Notes:
 A - Supplied on 2400 Series ONLY
 B - Replace retaining ring w/ alum. overlay on 8000 Series
 C - Contact factory for specific locations