

**H TYPE MINUTE IMPULSE  
MOVEMENT**

**DS-479C**

97 West Street, Medfield, MA 02052

p: 508.359.4396 f: 508.359.4482

[www.electrictime.com](http://www.electrictime.com)

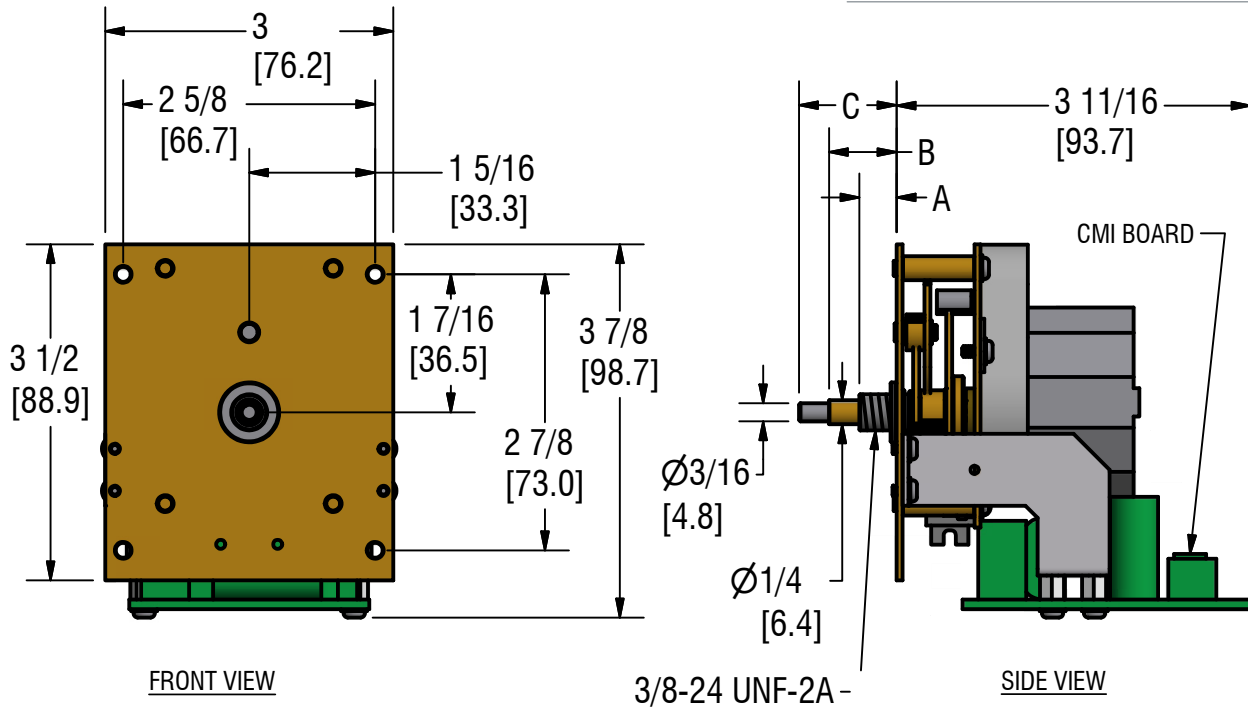

MECHANICAL SPECIFICATIONS

- UP TO  $\varnothing 30$ " [760] DIAL WITH UNPROTECTED HANDS (INDOORS ONLY)
- CONSULT ELECTRIC TIME CO. FOR RECOMMENDED MOVEMENT AND HAND MOUNTING PROCEDURES
- APPROXIMATE WEIGHT = 1LB

ELECTRICAL SPECIFICATIONS

- 24VAC-50/60 Hz-150mA-2.5W (MI MOTOR: 8sec/min RUN TIME)
- ALTERNATING DRIVE SIGNAL MINUTE IMPULSE OPERATION (USING ELECTRIC TIME CO. "MI" CLOCK CONTROLLER)

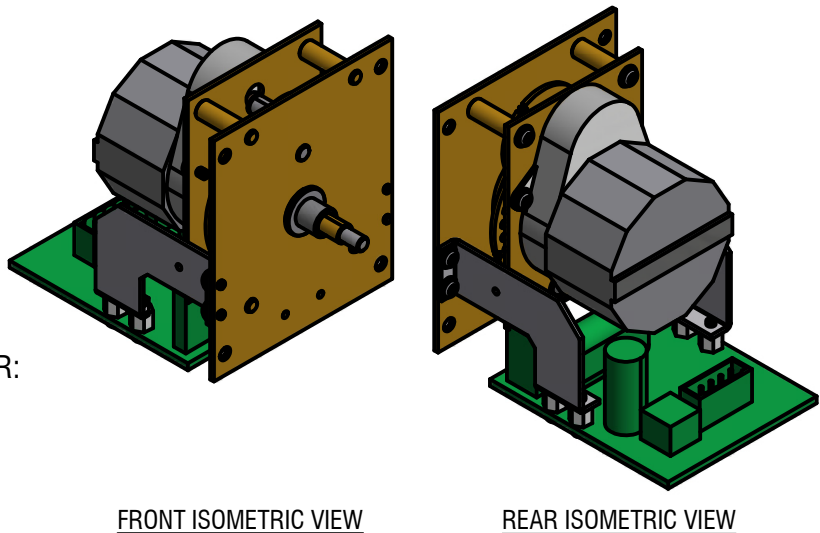

\*Sweep second hand version available  
consult Electric Time Co.

Note: Specifications subject  
to change without notice

PART NUMBER: MOVMT-HMI-

	A	B	C
<b>C4</b>	3/8 [ 9.5 ]	11/16 [ 17.5 ]	1 1/32 [ 26.2 ]
<b>C6</b>	27/32 [ 21.4 ]	1 13/32 [ 35.7 ]	1 7/8 [ 47.6 ]
<b>C8A</b>	1 7/8 [ 47.6 ]	2 3/16 [ 55.6 ]	2 1/2 [ 63.5 ]

ALL DIMENSIONS: INCHES [MILLIMETERS]