

C1 MINUTE IMPULSE STYLE SWEEP SECOND MOVEMENT

DS-41B

45 West Street, Medfield, MA 02052

p: 508.359.4396 f: 508.359.4482

www.electrictime.com

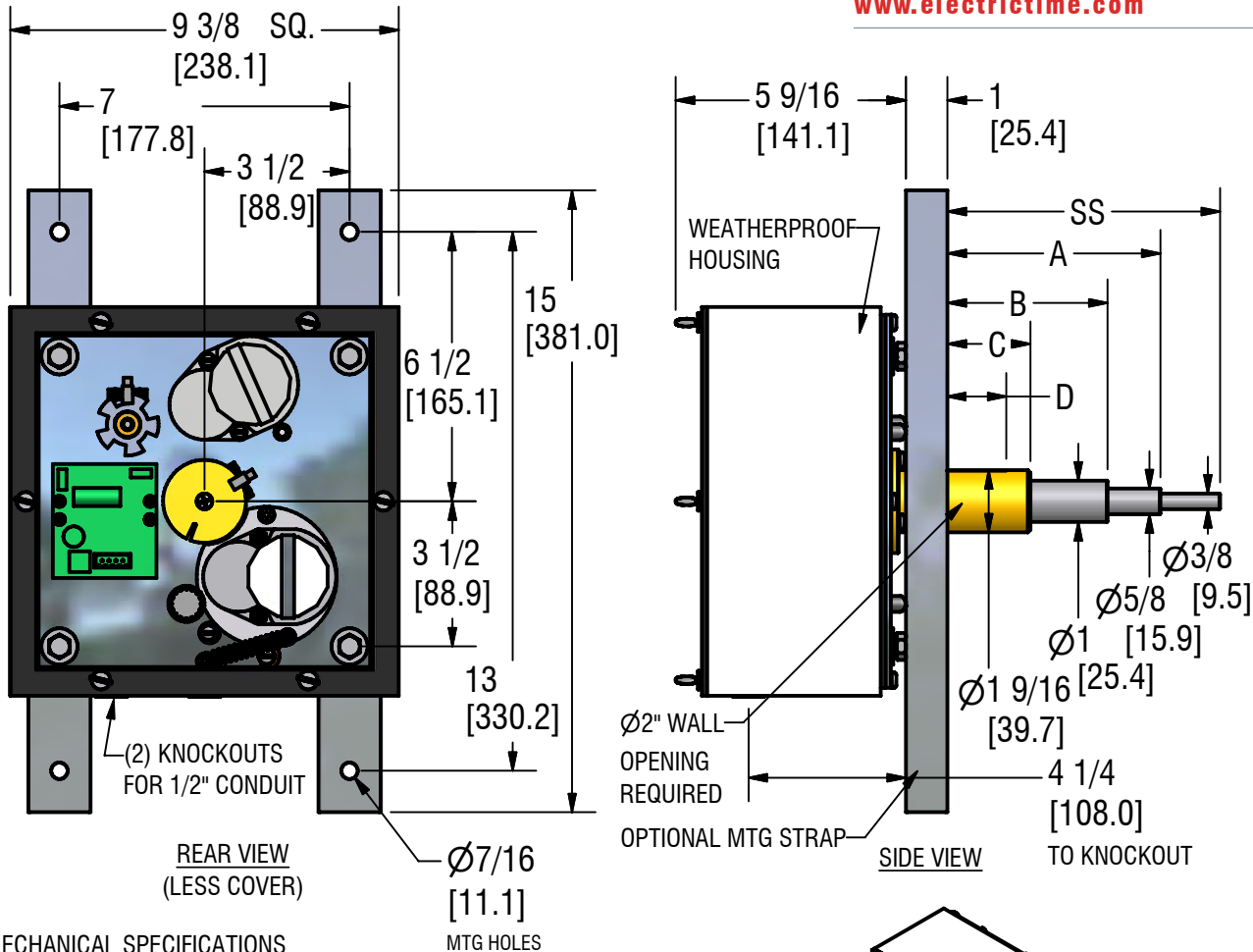

MECHANICAL SPECIFICATIONS

- UP TO $\varnothing 72$ " [1800] DIAL WITH UNPROTECTED HANDS (INDOORS ONLY)
- UP TO $\varnothing 96$ " [2400] DIAL WITH PROTECTED HANDS
- CONSULT ELECTRIC TIME CO. FOR RECOMMENDED MOVEMENT AND HAND MOUNTING PROCEDURES
- APPROXIMATE NET WEIGHT = 40 lbs

ELECTRICAL SPECIFICATIONS

- 24VAC-50/60 Hz-250mA-6W (MI MOTOR: 8sec/min RUN TIME)
- SS MOTOR: 24VAC 60 Hz 250mA 6W (CONTINUOUS DRIVE)
- ALTERNATING DRIVE SIGNAL MINUTE IMPULSE OPERATION (USING ELECTRIC TIME CO. 99B-MI CLOCK CONTROLLER)

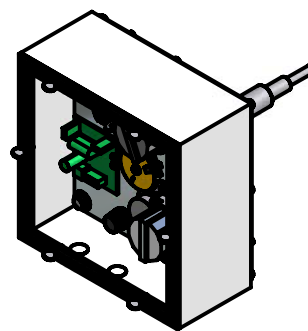

REAR ISOMETRIC VIEW
LESS COVER

PART NUMBER: MOV-T-C1MISS-

	A	B	C	D**	SS
G1	5 3/16 [131.8]	3 13/16 [96.8]	1 15/16 [49.2]	1 1/4 [31.8]	6 9/16 [166.7]
G3	8 5/8 [219.1]	7 1/4 [184.2]	5 3/8 [136.5]	5 [127.0]	10 [254.0]

Note: Specifications subject to change without notice

** MAX DIAL + WALL THICKNESS

ALL DIMENSIONS: INCHES [MILLIMETERS]