

97 West Street, Medfield, MA 02052

p: 508.359.4396 f: 508.359.4482

www.electrictime.com

DESCRIPTION

The bell hammer actuator is designed as a non intrusive means to automate an existing bell and hammer setup. At the top of the hour the hammer is raised and released to strike the bell just as if someone were pulling and releasing a rope. This setup maintains the original sound quality and preserves the original bell and hammer.

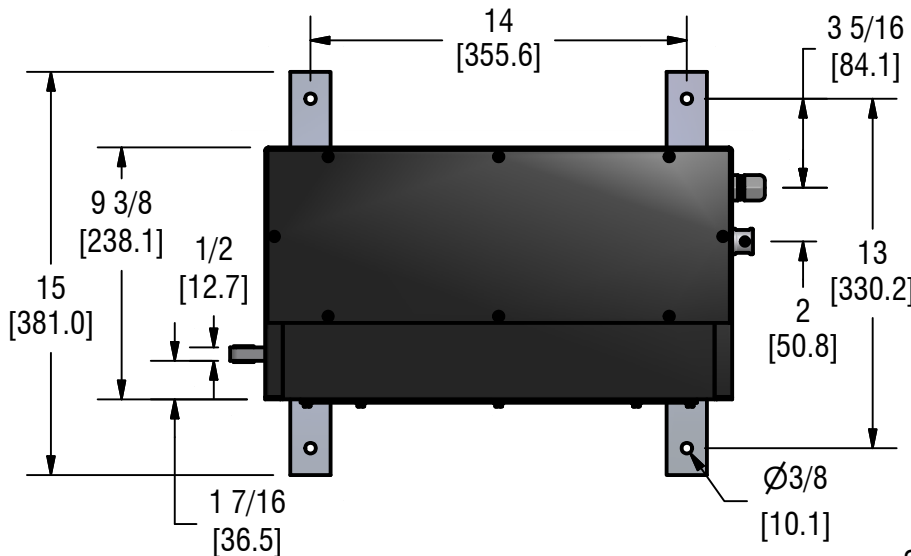

PART NUMBER:
BELL-HMR-ACT-35

SPECIFICATIONS

- Up to 35lb bell hammer (push or pull)
- "Normally up" or "normally down" operation
- 2 sec minimum between consecutive bell strikes
- Pull distance adjusts between 2-8"
- Consult Electric Time Co. for mounting and connection details
- 115VAC, 3A required. Optional: 220VAC, 1.5A (motor operation)
- 24VAC Hour strike signal required from Electric Time Co. 99B-MI Clock Controller

Note: Specifications subject to change without notice