

H TYPE MINUTE IMPULSE MOVEMENT

DS-479B

45 West Street, Medfield, MA 02052

p: 508.359.4396 f: 508.359.4482

www.electrictime.com

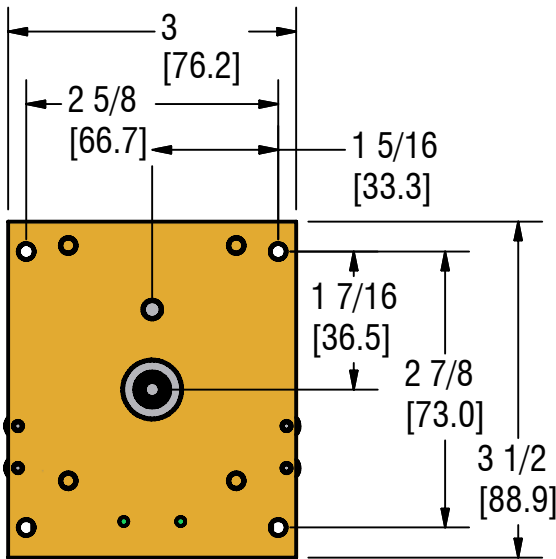

FRONT VIEW

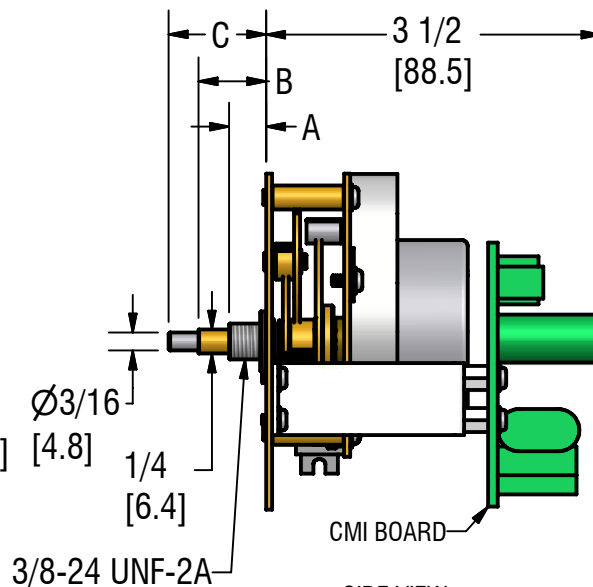

SIDE VIEW

MECHANICAL SPECIFICATIONS

- UP TO $\varnothing 30$ " [760] DIAL WITH UNPROTECTED HANDS (INDOORS ONLY)
- CONSULT ELECTRIC TIME CO. FOR RECOMMENDED MOVEMENT AND HAND MOUNTING PROCEDURES
- APPROXIMATE WEIGHT = 1LB

ELECTRICAL SPECIFICATIONS

- 24VAC-50/60 Hz-150mA-2.5W (MI MOTOR: 8sec/min RUN TIME)
- ALTERNATING DRIVE SIGNAL MINUTE IMPULSE OPERATION (USING ELECTRIC TIME CO. 99B-MI CLOCK CONTROLLER)

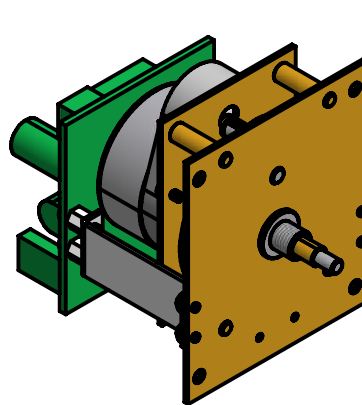

FRONT ISOMETRIC VIEW

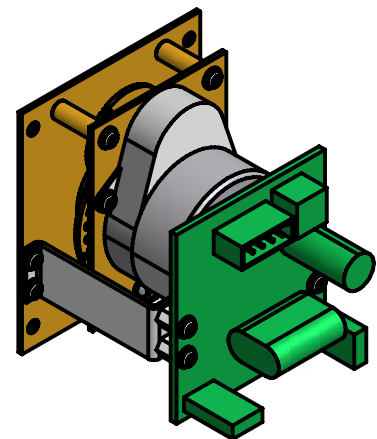

REAR ISOMETRIC VIEW

*Sweep second hand version available
consult Electric Time Co.

Note: Specifications subject
to change without notice

PART NUMBER: MOVMT-HMI-

	A	B	C
C4	3/8 [9.5]	11/16 [17.5]	1 1/32 [26.2]
C6	27/32 [21.4]	1 13/32 [35.7]	1 7/8 [47.6]
C8A	1 7/8 [47.6]	2 3/16 [55.6]	2 1/2 [63.5]

ALL DIMENSIONS: INCHES [MILLIMETERS]